

ESV

SINGLE DUCT TERMINALS - DIMENSIONAL DATA

MODEL: **PESV**
Pneumatic Control

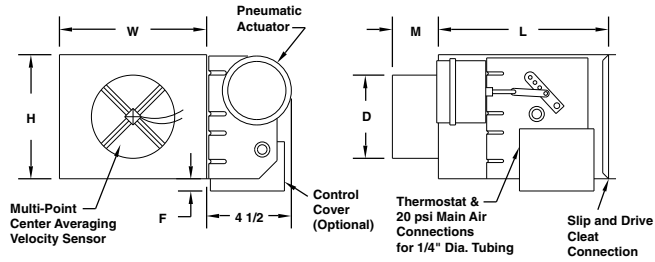

MODEL: **AESV**
Electronic Control

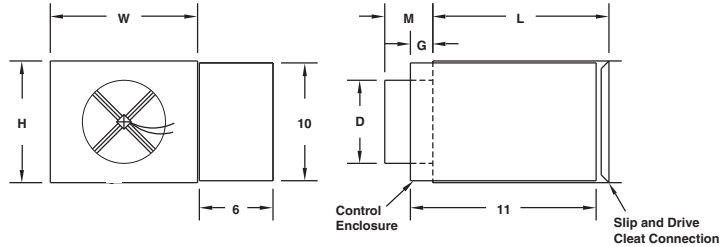

MODEL: **DESV**
DDC Control

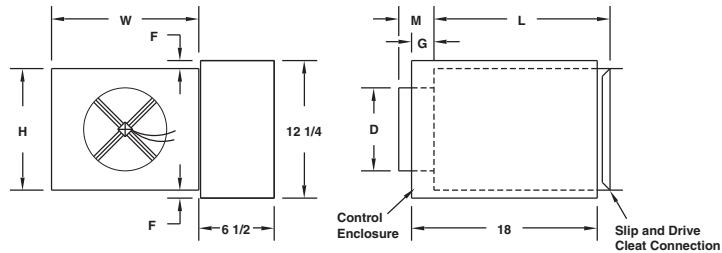

Inlet Size	cfm Range	D	L	W	H	F			M
						DESV	PESV	DESV	PESV DESV
6	0 - 500	5 7/8	15 1/2	12	8	7 7/16	3 9/16	2 1/8	3 3/8
8	0 - 900	7 7/8	15 1/2	12	10	5 7/16	2 9/16	1 1/8	3 3/8
10	0 - 1400	9 7/8	15 1/2	14	12 1/2	5 7/16	9/16	—	3 3/8
12	0 - 2000	11 7/8	15 1/2	16	15	5 7/16	—	—	3 3/8
14	0 - 3000	9 7/8	15 1/2	20	17 1/2	3 7/16	—	—	3 3/8
16	0 - 4000	11 7/8	15 1/2	24	18	3 7/16	—	—	3 3/8

- For optimum control, the inlet duct must be the same size as the unit inlet.
- Right hand control location, as shown above, is standard. Left hand is optional.
- All dimensions are in inches.

HOT WATER COILS FOR SINGLE DUCT TERMINALS

Note: All products are available with pneumatic or analog controls, or enclosure for field mounting of DDC controls.

Inlet Size	W	H	L (1-2 Row)
6	12	8	5
8	12	10	5
10	14	12 1/2	5
12	16	15	5
14	20	17 1/2	7 1/2
16	24	18	7 1/2

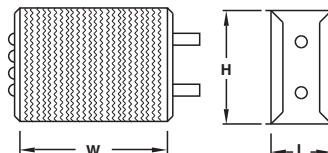

HOT WATER COIL

The hot water coil is enclosed in a galvanized steel casing module to match the basic terminal unit.

- Water coil connections: Single circuit is 1/2" OD male solder. Multiple circuit is 7/8" OD male solder.
- Dimensions are in inches.
- Available in 1 and 2 rows.

TQS

SERIES FAN CONSTANT VOLUME TERMINALS

BASIC UNIT

- Quiet, Efficient Operation
- Pressure Independent Airflow Control
- Available from 300-3200 cfm Flow Range

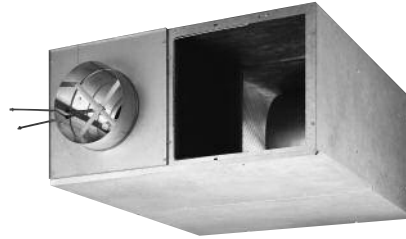

TQP

PARALLEL FAN CONSTANT VOLUME TERMINALS

BASIC UNIT

- Quiet, Efficient Operation
- Pressure Independent Airflow Control
- Available from 300-2000 cfm Fan Flow Range

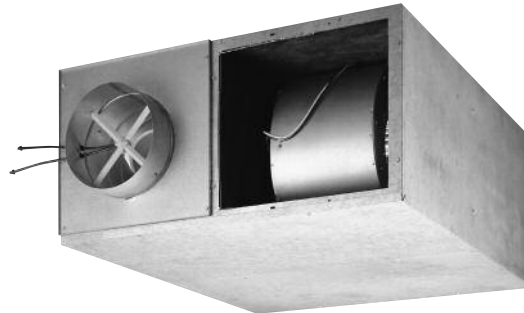

ACCESSORIES

Add for T-Stat and Transformer	
CTE 5101	Cooling Only
CTE 5103	Cooling/Heating/Auto Chg
CTE 5104	Cooling w/ Reheat/Aux Ht
Transformer 120v to 24v	
Transformer 277v to 24v	

Note: Analog Controller is Titus TA-1.

Sizes Currently Stocked	
Sizes	Heat (1)
206, 208, & 210	No Heat
306, 308, & 310	No Heat
312	No Heat
408 & 410	No Heat
412	No Heat
510 & 512	No Heat
514 & 516	No Heat
206, 208, & 210	5 KW
306, 308, & 310	7 KW
312	7 KW
408 & 410	10 KW
412 & 414 (2)	10 KW
510 & 512	15 KW
514 & 516	15 KW
206, 208, & 210	2 Row HWC
306, 308, & 310	2 Row HWC
312	2 Row HWC
408 & 410	2 Row HWC
412 & 414 (2)	2 Row HWC
510 & 512	2 Row HWC
514 & 516	2 Row HWC

All products are available with pneumatic or analog controls, or enclosure for field mounting of DDC controls.

(1) All electric heat is 2-stage.

(2) Size 414 not available with pneumatic controls.

Note: Fan Motor 277/1/60
Electric Heat 460/3/60



VAV Terminals/Fan Powered

TQS

FAN POWERED
SERIES TYPE -
QUIET OPERATION

MODELS:

PTQS

- Pneumatic Control

ATQS

- Analog Control

DTQS

- Digital Control
(for field install of controls)

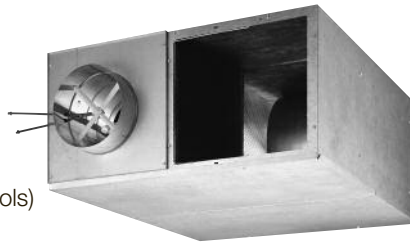

DTQS: Sizes 2-5

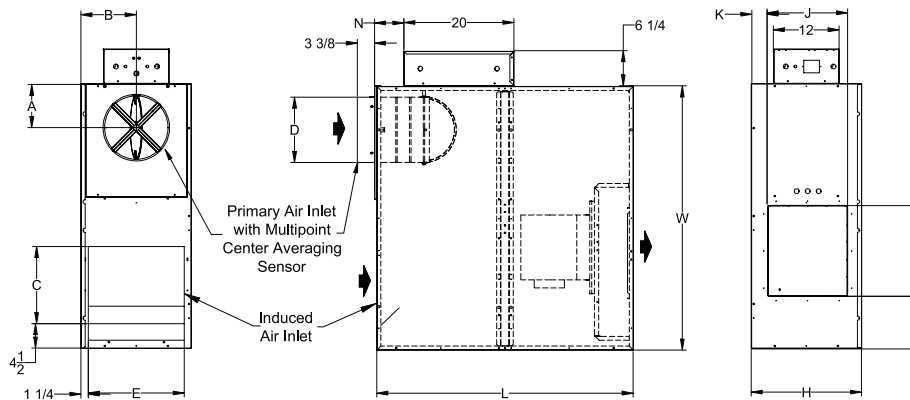

- Consistent, quiet design
- 2 casings for easy design layout
- Built-in sound baffle for low sound levels, both radiated and discharge
- Pressure independent primary airflow control
- Multi-point inlet velocity sensor with center averaging
- Energy efficient fan motor, permanent split capacitor type, mounted with vibration isolators
- Adjustable SCR fan speed control with minimum voltage stop
- Single point electrical, pneumatic main, and thermostat connections
- Dual density insulation, coated to prevent air erosion, meets requirements of NFPA 90A and UL 181
- 20 gauge, galvanized steel casing
- Rectangular discharge opening is designed for flanged duct connections
- Bottom access panel can be removed for service
- No external sound attenuators are required

* Size 414 not available with pneumatic controls.

Model TQS Parallel Unit															
Size	Inlet Size	A	B	C	D	E	F	G	H	J	K	L	N	W	Filter Size
2, 3	6	6	8 9/16	13 1/4	5 7/8	14 1/2	14	8 1/2	17 1/8	11	4	40 7/8	2 7/8	36 1/8	19x17
	8	6			7 7/8								2 7/8		
	10	7			9 7/8								4 7/8		
4	8	6	8 9/16	13 1/4	7 7/8	14 1/2	14	8 1/2	17 1/8	11	4	40 7/8	2 7/8	36 1/8	19x17
	10	7			9 7/8								4 7/8		
	12	8			11 7/8								4 7/8		
	* 14	10			13 7/8								6 7/8		
5	10	7	10 1/16	21	9 7/8	17 1/2	16 1/2	9 1/2	20 1/8	14 1/2	2 1/2	46 7/8	4 7/8	48 1/8	27x20
	12	8			11 7/8								4 7/8		
	14	10			13 7/8								6 7/8		
	16	11			15 7/8								6 7/8		

All dimensions are in inches.

TQS HOT WATER COIL SECTION STANDARD FEATURES

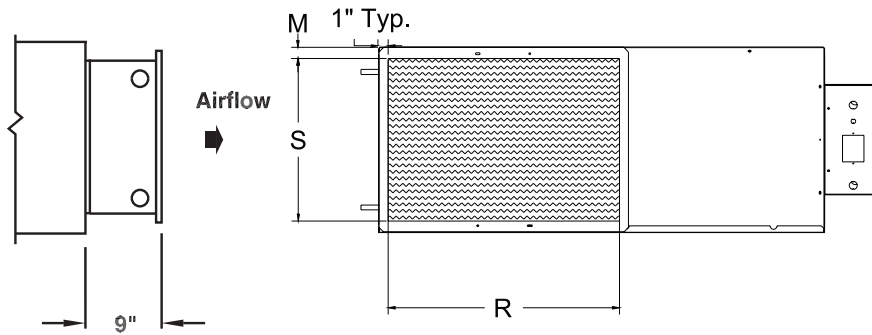

- 1/2" copper tubes
- Aluminum ripple fins
- Connections: Male solder; 5/8" for both 1-row and 2-row; left or right hand connections
- Galvanized steel casing
- Flanged duct connection
- Coil is installed at discharge of unit

* Note: R and S are inside dimensions.

Hot Water Coil Section (Discharge Mounted)

Unit Size	M (2 ROW)	R	S
2, 3, 4	1 1/4	17	15
5	1 1/4	25	17 1/2

Coil Rows

- 2-Row

TQS ELECTRIC COIL SECTION STANDARD FEATURES

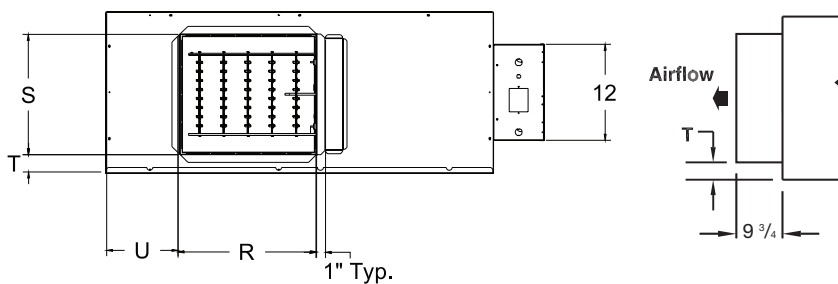

- Automatic reset thermal cutouts, one per element
- Single point electrical connection for entire unit, including coil
- Positive pressure airflow switch
- Flanged duct connection
- Coil is installed at discharge of unit
- Preset P/E switches with pneumatic units

Supply Voltage

- 277V / 1 ph / 60 Hz.
- 480V / 3 ph / 60 Hz. (4 wire wye)

Electric Coil Section (Discharge Mounted)

Unit Size	R	S	T	U
2, 3, 4	14	11	2 1/8	3 1/2
5	16 1/2	14 1/2	3 1/8	9 1/2

* Note: R and S are inside dimensions.

Options

- Disconnect switch, door interlock type

ELECTRICAL DATA

Unit Size	Motor HP	277V
		FLA
2	1/6	1.3
3	1/4	2.4
4	1/3	2.9
5	1/3	3.3

ADDITIONAL ACCESSORIES (OPTIONAL)

- Induced air filter, 1" thick disposable construction type
- Fan disconnect switch (not available on units with optional electric coils)
- Metal controller cover.

All motors are single phase, 60(Hz).

FLA = Full Load Amperage, as tested in accordance with UL 1995. 277V motors are used with 480V 3 Phase coils (four wire wye).



VAV Terminals/Fan Powered

AIRFLOW VS. DOWNSTREAM STATIC PRESSURE

MODELS:

PTQS

ATQS

DTQS

No Coil or with Electric Coil ———
 1 Row Water Coil - - - - -
 2 Row Water Coil

Unit Size 2

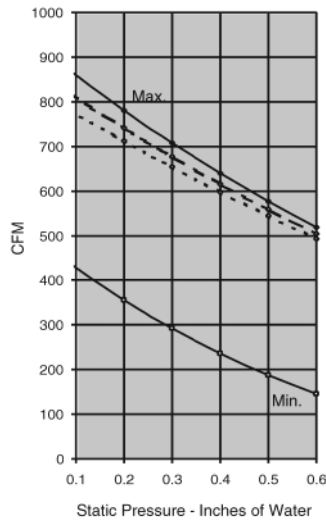

Unit Size 3

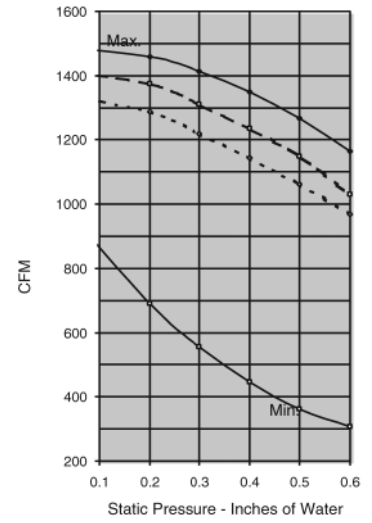

Unit Size 4

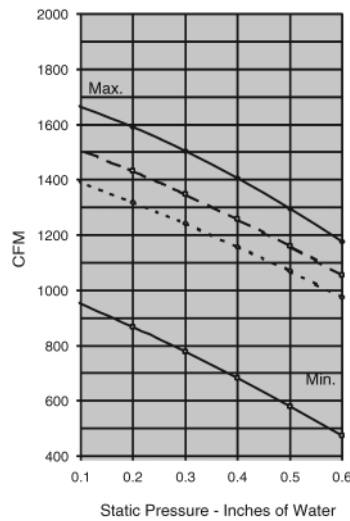

Unit Size 5

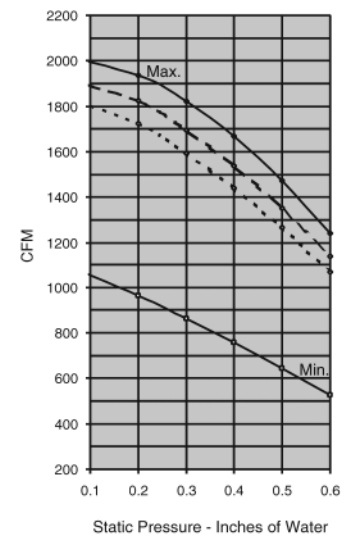

PRIMARY AIR INLET PRESSURE

PTQS

ATQS

DTQS

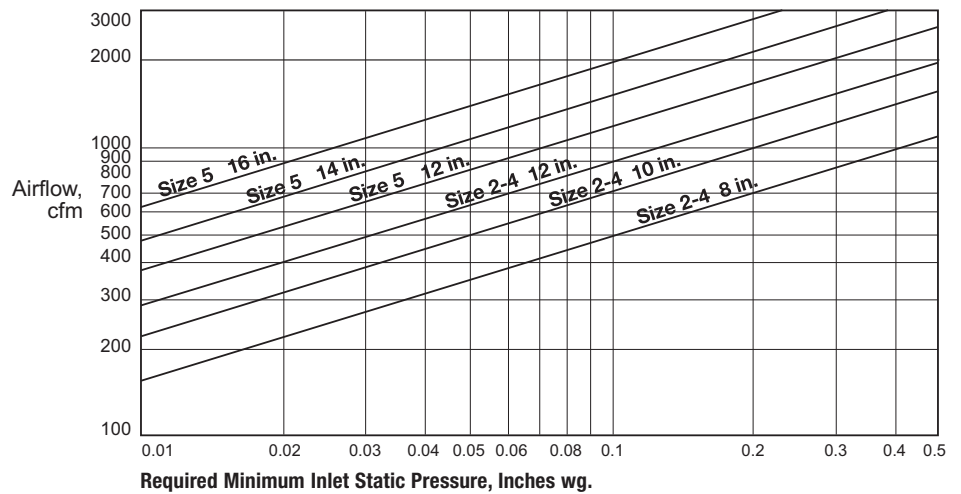



TQP

FAN POWERED
PARALLEL TYPE –
PARALLEL FLOW

MODELS:

- PTQP**
- Pneumatic Control
- ATQP**
- Analog Control
- DTQP**
- Digital Control (for field install of controls)

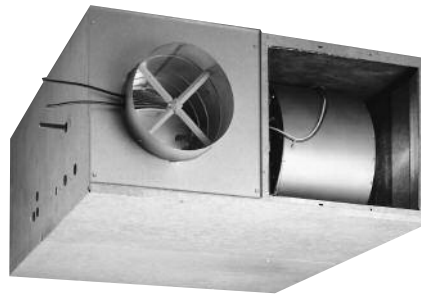

- 2 casing sizes ease in design layout
- Pressure independent primary airflow control
- Multi-point, center averaging inlet velocity sensor
- Primary airflow balancing connections
- Adjustments are easily accessible through ceiling opening
- Energy efficient fan motor, permanent split capacitor type mounted with vibration isolators
- Adjustable SCR fan speed control with minimum voltage stop
- Single point electrical, pneumatic main, and thermostat connections
- Dual density insulation, coated to prevent air erosion, meets requirements of NFPA 90A and UL 181
- 20 gauge, galvanized steel casing with leak resistant construction
- Rectangular discharge opening is designed for flanged duct connections
- Bottom access panel can be removed for service

DTQP: Sizes 2-5

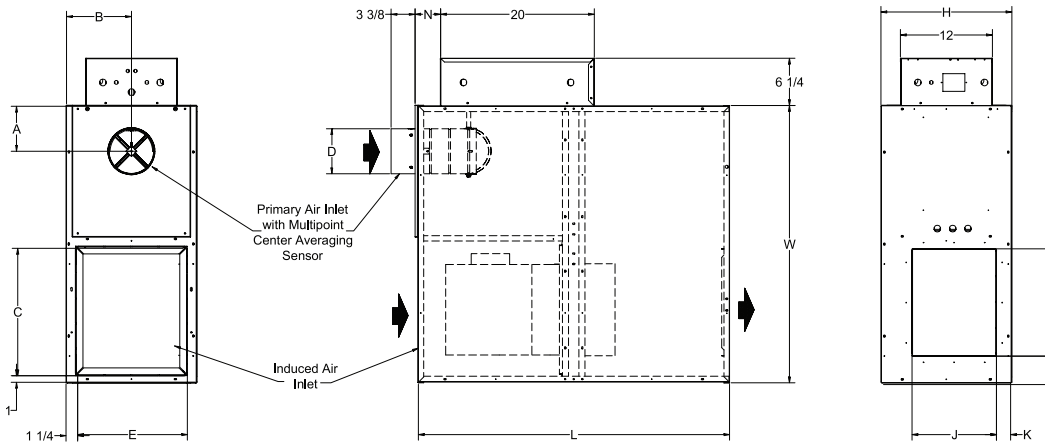

* Size 414 not available with pneumatic controls.

All dimensions are in inches. Filter size is for unit without attenuator.

Model TQP Parallel Unit															
Size	Inlet Size	A	B	C	D	E	F	G	H	J	K	L	W	N	Filter Size
2, 3	6	6	8 9/16	16 3/4	5 7/8	14 1/2	14	3 1/2	17 1/8	11	2 1/8	40 7/8	36 1/8	2 7/8	19x17
	8	6			7 7/8									2 7/8	
	10	7			9 7/8									4 7/8	
4	8	6			7 7/8									2 7/8	
	10	7			9 7/8									4 7/8	
	12	8			11 7/8									4 7/8	
	*14	10	13 7/8	6 7/8											
5	10	7	10 1/16	24 1/2	9 7/8	17 1/2	16 1/2	9 1/2	20 1/8	14 1/2	3 1/8	46 7/8	48 1/8	4 7/8	27x20
	12	8			11 7/8									4 7/8	
	14	10			13 7/8									6 7/8	
	16	11			15 7/8									6 7/8	

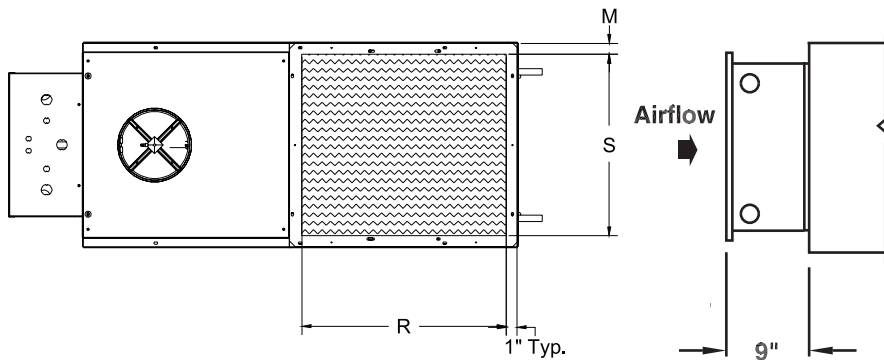

Hot Water Coil Section (Inlet Mounted)

* Note: R and S are inside dimensions.

Unit Size	M (2 ROW)	R	S
2, 3, 4	1 1/4	17	15
5	1 1/4	25	17

All dimensions are in inches.

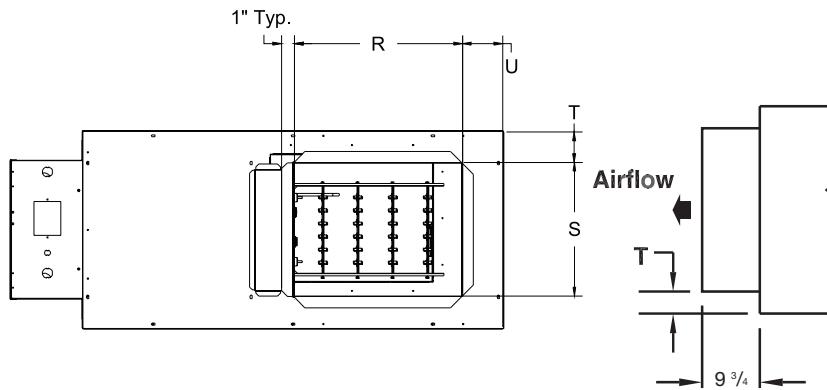

Electric Coil Section (Discharge Mounted)

Supply Voltage

- 277V / 1 ph / 60 Hz
- 480V / 3 ph / 60 Hz (4 wire wye only)

* Note: R and S are inside dimensions.

Unit Size	R	S	T	U
2, 3, 4	14	11	2 1/8	1
5	16 1/2	14 1/2	3 1/8	6

Note: Coil control box replaces standard terminal unit control box.
All dimensions are in inches.

TQP HOT WATER COIL SECTION

STANDARD FEATURES

- 1/2" copper tubes
- Aluminum ripple fins, 10 per inch
- Connections: Male solder, 1 row 5/8", 2 row 5/8"; right hand only
- Galvanized steel casing
- Flanged duct connection
- Coil is installed at induced air inlet

Coil Rows

- 2 Row

TQP ELECTRIC COIL SECTION

STANDARD FEATURES

- Automatic reset thermal cutouts, one per element
- Single point electrical connection
- Positive pressure airflow switch
- Flanged duct connection
- Coil is installed at discharge of unit
- Disconnect switch, door interlock type
- Preset P/E switches with pneumatic units

ELECTRICAL DATA

Unit Size	Motor Horse-power	Motor Amperage Ratings
		277/1/60 FLA
2	1/6	1.3
3	1/4	2.2
4	1/3	2.9
5	1/3	3.2

FLA = Full Load Amperage, as tested in accordance with UL 1995.

277 voltage motors are used with 480 volt / 3 phase coil (4 wire wye).



Inlet Size	Total cfm Range	TITUS II, IIA Pneumatic Controller		TITUS TA1 Analog Electronic Controller	
		Minimum	Maximum	Minimum	Maximum
6	0-500	*80-330	150-500	*80-500	80-500
8	0-900	*145-590	265-900	*145-900	145-900
10	0-1400	*230-925	415-1400	*230-1400	230-1400
12	0-2000	*325-1330	600-2000	*325-2000	325-2000
14	0-3000	*450-1800	840-3000	*450-3000	450-3000
16	0-4000	*580-2350	1100-4000	*580-4000	580-4000

PRIMARY AIR CFM RANGES

* Factory cfm settings (except zero) will not be made below this range because control accuracy is reduced. On pressure dependent units, minimum cfm is always zero and there is no maximum.

PRIMARY AIR INLET PRESSURES • PTQP, ATQP, DTQP

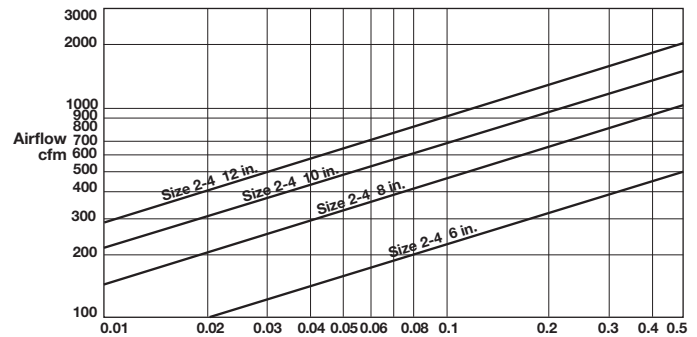
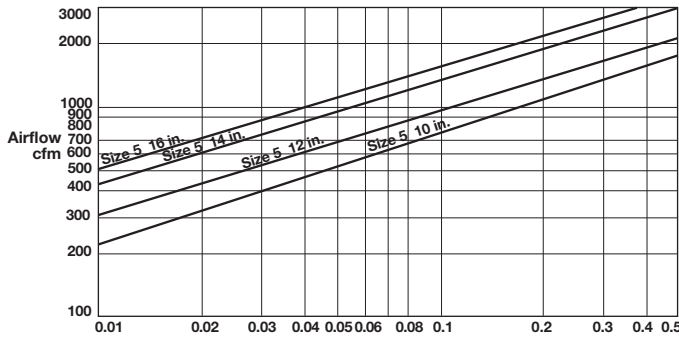

REQUIRED MINIMUM INLET STATIC PRESSURE, INCHES WG.

MODELS: PTQP, ATQP, DTQP • AIRFLOW VS. DOWNSTREAM STATIC PRESSURE

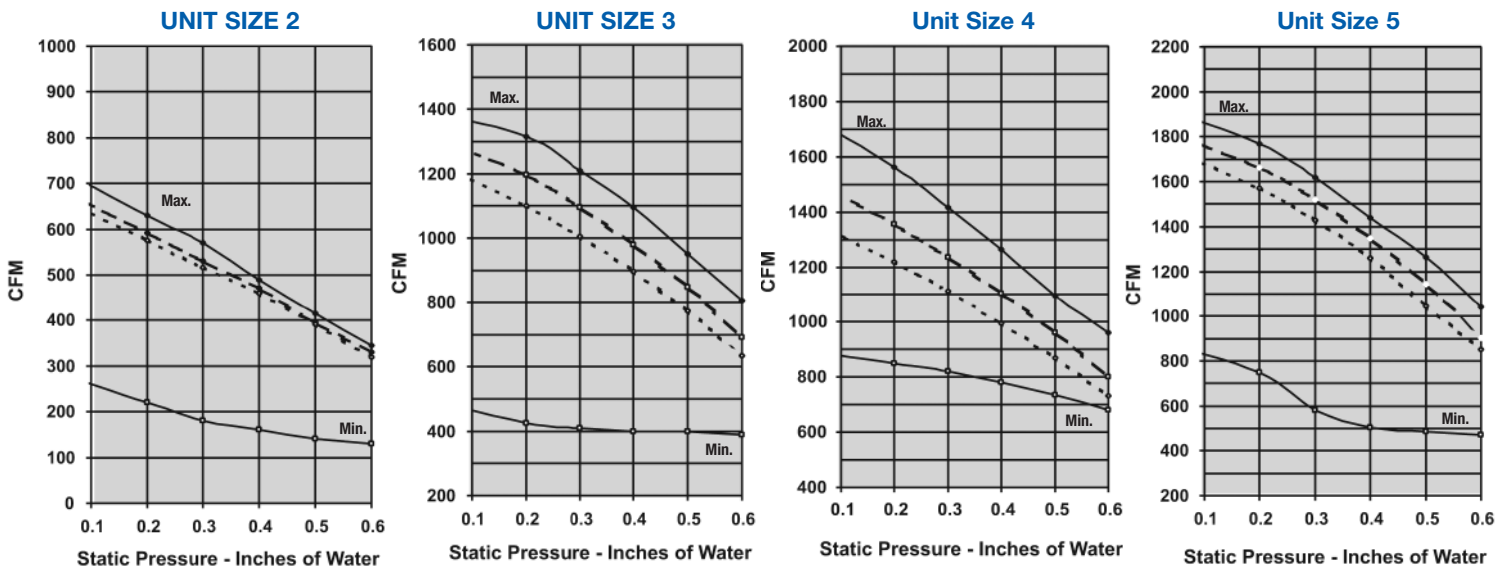

No Coil or with Electric Coil ———
 1 Row Water Coil - - - - -
 2 Row Water Coil - - - - -



VAV Terminals/Digital, Analog Electronic and Pneumatic Controls

DDC ELECTRONIC CONTROLS

ADW MOUNTS AND WIRES DDC CONTROLS

Save money and time. Need a fast turnaround on single duct or fan-powered terminals, with DDC controls mounted, wired and ready to go? ADW has experience mounting almost every brand of DDC controls on Titus terminals, using factory-generated wiring diagrams. Call us today!

ANALOG ELECTRONIC CONTROLS

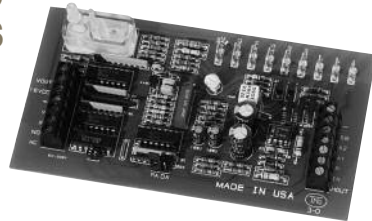

CONTROLLER FEATURES

- Multi-point, center averaging velocity sensor for accuracy
- Platinum/ceramic flow through transducer for reliability
- Snaptrack mounting for easy serviceability
- One model handles all standard control strategies
- Pressure independent VAV damper control
- Constant or intermittent fan stage sequencing
- Operates up to three stages of reheat
- Controls 0–10 Vdc proportional hot water valves
- Controls 24 Vac on/off auxiliary heat
- Automatic changeover capability
- Temperature setback available

THERMOSTAT FEATURES

- Contains all adjustments for easy balancing
- Bi-metallic temperature indicator
- Minimum, maximum, and auxiliary flow limit adjustments
- Live velocity readout terminal
- Tamper-proof cover with hidden setpoint sliders

ACTUATOR FEATURES

- 24 Vac tri-state damper actuator
- Rugged construction
- No stall design featuring magnetic clutch
- Linkage release button
- 50 in.-lb. minimum torque rating
- 5 minute full stroke time

PNEUMATIC CONTROLS



CONTROLLER FEATURES

- Accurate control over a duct velocity range of 0–3000 fpm
- Operates at low system pressures; as effective at 0.03" Ps as at 6.0" Ps
- Pressure independent
- Reset span remains constant regardless of maximum and minimum cfm adjustments; the factory set 5 psi span is adjustable from 3 -10 psi to match any thermostat
- Reset start point is adjustable from 3–13 psi to work with accessories such as reheat coils (factory setting is 8 psi)
- Thermostat switch changes the action from direct acting to reverse acting without additional calibration; no additional relays required—great for quick retrofit installation
- Damper switch changes the operation of the control from normally open to normally closed without re-calibration; no additional relays required
- All adjustments are made with a hex shanked knob stored in the face of the TITUS II controller
- Operates on a control air pressure of 15–25 psi
- Control air consumption is no more than 1.2 scfh